

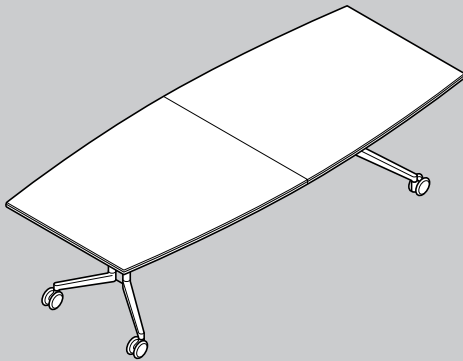

Chromium-plated, polished or coated, on glides or with adjustable castors - the frame versions of the three table ranges are customized to meet relevant requirements.

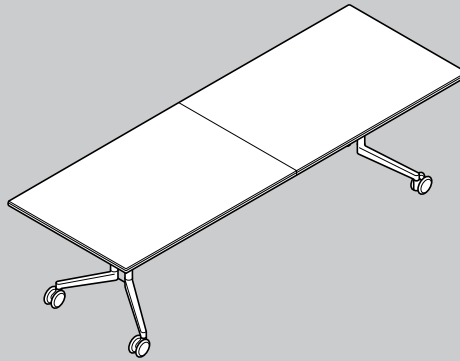

440/2 folding table
(440/1 with utensil trays),
barrel-shaped form, 110 x 260



440/21 folding table
(440/11 with utensil trays),
rectangular form, 90 x 260

Confair folding table
440 range

Mobile, single, folding tables for conference and training environments.

Frame
Foot section in die-cast aluminium, chromium-plated, polished or colour coated; uprights in anodized aluminium or colour coated; underframe in aluminium, coated in the colour platinum or black; lockable swivel castors in black polyamide. Optional utensil trays in black ABS plastic.

Table tops
Laminboard with laminated wood lipping and integral, impact-resilient profile in black polypropylene.

Surface finish
Laminate, wood veneer or linoleum according to colour samples.

Accessories
Snap connectors for linking several folding tables.

Timetable
610 range

Mobile, single, pivotable tables, allowing compact storage, for seminar and office environments.

Frame
Foot section in die-cast aluminium, chromium-plated or polished; pivotable uprights and underframe in steel, coated in the colour platinum or black; lockable swivel castors in black polyamide.

Table tops
Particle board with laminated wood lipping and integral, impact-resilient profile in black polypropylene.

Surface finish
Laminate or wood veneer according to colour samples.

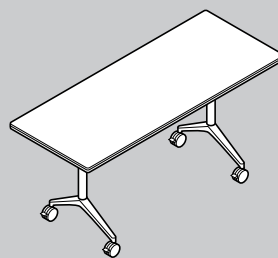

Model group **610**: 60 x 150/225

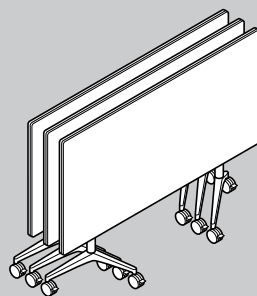

Model group **612**: 75 x 150/225

Manufacturing Centre offers special sizes, forms and surface finishes for individually customized configurations, in addition to the models shown for the Logon, Confair folding table and Timetable ranges.

All dimensions in cm